

FSM SERIES

Type of Explosion-Proof
Flameproof (Ex d IIB+H2 T6)

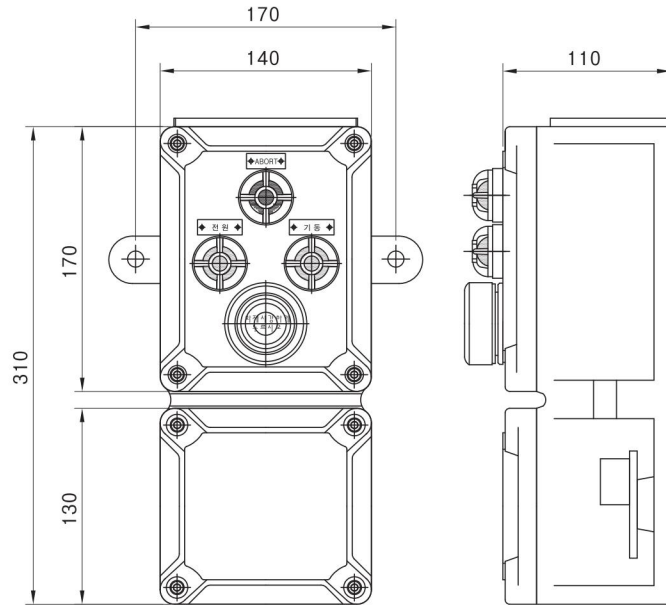

Standard Materials

- Body : Cast aluminium alloy
- Cover : Cast aluminium alloy
- Bolt & Washer : Stainless Steel



Technical Data

- Rated Voltage : AC 110V,220V / DC12V,24V



Standard Finish

- MUNSELL No. 7.5R 3/12
- If you want another color, contact us please.



Compliance & Certification

- IEC 60079-0,1
- Notification of Ministry of Labor No.2010-36
- Certified by KGS (Korea Gas Safety Corporation)